

Rev.	Description	Initiator	Date
01	Initial Drawing	JMW	11/25/2013

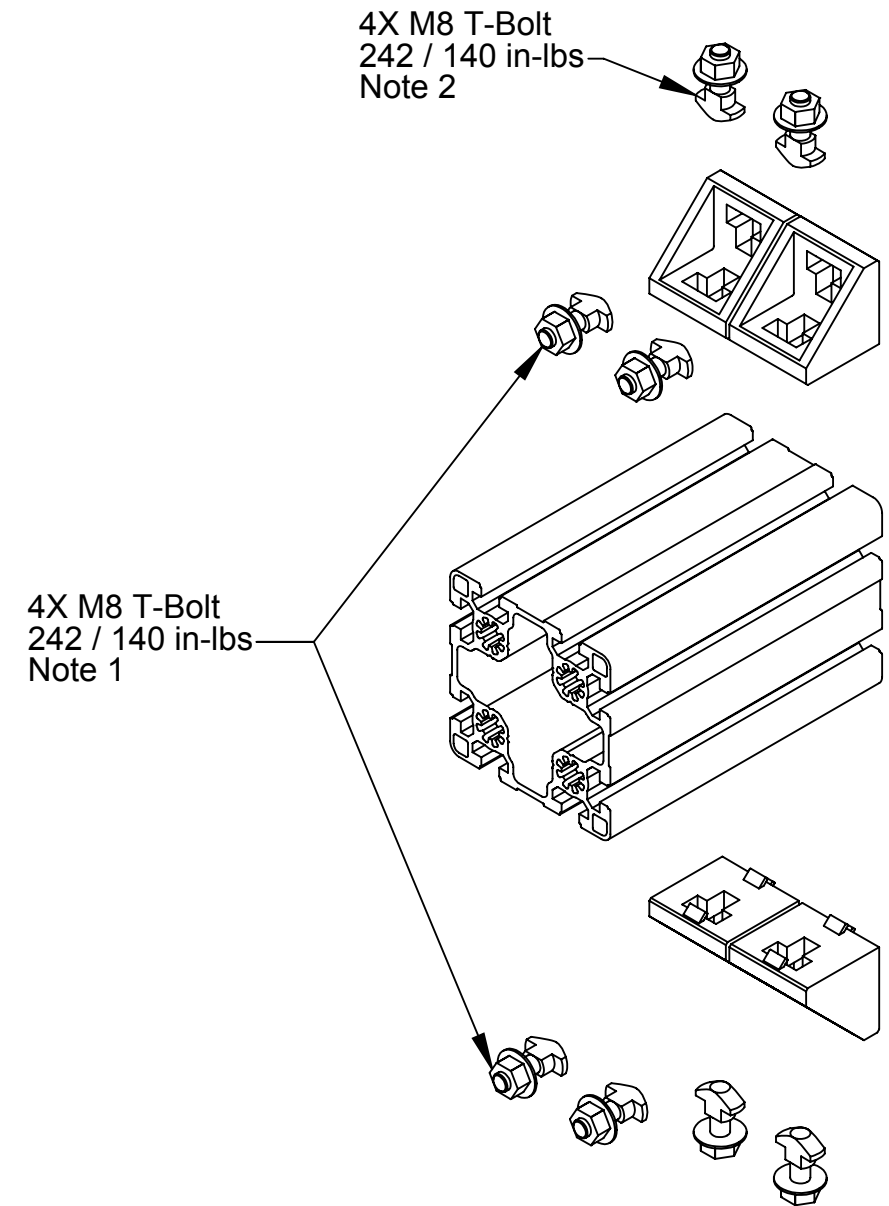
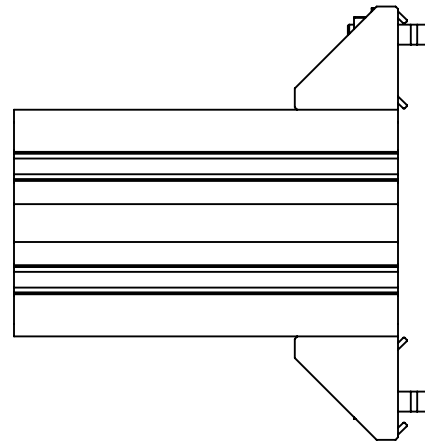
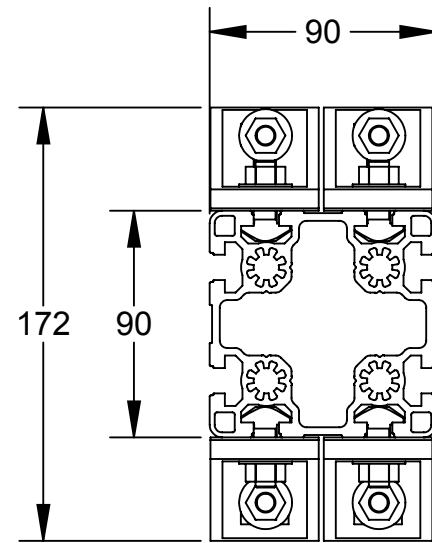
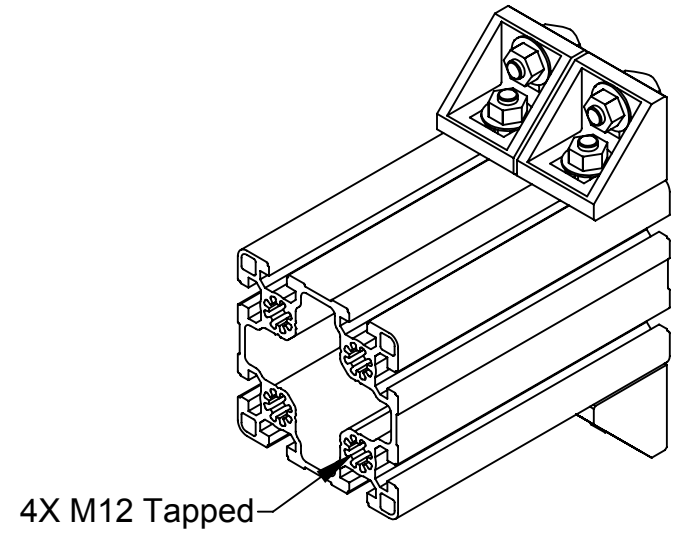
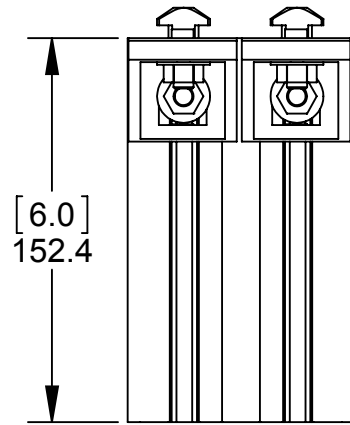

**Notes:**

1. Supplied hand tight w/o threadlocker. Customer to use Loctite or similar threadlocker and torque fasteners to listed torque value.
2. Customer to use Loctite or similar threadlocker and torque fasteners to listed torque value.

NOTES: UNLESS OTHERWISE SPECIFIED.

DO NOT SCALE DRAWING. ALL DIMENSIONS ARE IN MILLIMETERS.



3rd ANGLE PROJECTION

ITEM NO.	QTY.	PART NUMBER	DESCRIPTION
1	1	9120-TSM-HE-3320	TSM Horizontal Extension, 6"



**ATI INDUSTRIAL AUTOMATION**

1031 Goodworth Drive, Apex, NC 27539, USA  
 Tel: +1.919.772.0115 Email: info@ati-ia.com  
 Fax: +1.919.772.8259 www.ati-ia.com  
 ISO 9001 Registered Company

PROPERTY OF ATI INDUSTRIAL AUTOMATION, INC. NOT TO BE REPRODUCED IN ANY MANNER EXCEPT ON ORDER OR WITH PRIOR WRITTEN AUTHORIZATION OF ATI.

DRAWN BY: J. Winterroth, 11/25/13		TITLE	
CHECKED BY: D. Norton, 12/04/13		TSM Horizontal Extension, 6"	
PROJECT # -	SHEET 1 OF 1	SCALE	SIZE
		1:3	B
		DRAWING NUMBER	REVISION
		9630-20-TSM-HE-3320	01